

Mounting Guideline for Golden DRAGON[®] with Lens

Application Note

Abstract

The following application note represents a general guideline for mounting LEDs of the Golden DRAGON[®] with Lens product family. A basic overview of the construction of LEDs and important design rules for the development of LED systems are provided.

In addition, the principal processing steps are illustrated for the Golden DRAGON[®] ARGUS[®] LED, and general information about mounting is summarized.

In the following, a recommended selective soldering method by means of laser diodes is also introduced, because it is not possible to process these LED type with a conventional standard soldering process. Thereby the important process parameters and steps for processing of the Golden DRAGON[®] ARGUS[®] LED are described.

In a final manner alternative solder techniques are presented.

Introduction

With the availability of new high power LEDs, new application areas have been opened which were previously reserved to conventional lamps. These high power LEDs are based on new highly efficient chip technologies in combination with thermally optimized device packages.

In many cases LEDs must be fitted with additional optics attached to the LED, and/or within the system to be able to fulfill the requirements of the specific applications.

In that connection the main task of lenses is to adapt the nearly point-formed LED light source to the application related requirements.

Typically, light emitting diodes (LEDs) are mounted to the circuit board using standard

soldering methods such as IR reflow or wave soldering. Due to their low melting point, however, optical plastics are not able to withstand the thermal stresses which arise during soldering. The lens body becomes deformed, ultimately leading to failure of the LED.

In the following, an example is provided for the Golden DRAGON[®] ARGUS[®] LED, a high power LED with lens, in which important design rules for the construction of LED systems as well as basic tips about mounting for processing are presented.

Furthermore, the recommended selective laser soldering method is introduced and important process parameters and steps for the Golden DRAGON[®] ARGUS[®] LED are described.

Construction and Design Rules

Golden DRAGON[®] ARGUS[®]

The Golden DRAGON[®] ARGUS[®] is based on the high power package of the Golden DRAGON[®] LED combined with a special wide-radiating ARGUS[®] lens (Figure 1).

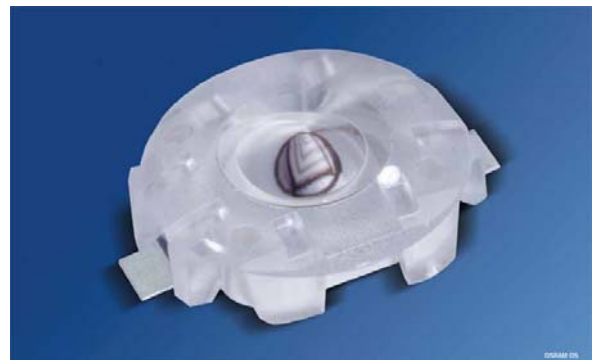

Figure 1: Golden DRAGON[®] ARGUS[®] LED

The LED is particularly well suited for uniform illumination of large areas. For direct backlighting of large screen TV displays or to serve as the basis for LCD panels or billboards it represents the ideal LED backlight product.

The basic model - the housing of the Golden DRAGON® (Figure 2) - is suited for standard SMT soldering methods such as reflow or vapor phase soldering.



Figure 2: Basic model of the Golden DRAGON® LED family

With the Golden DRAGON® ARGUS® LED, however, the maximum processing temperature is limited to 125 °C. Standard soldering processes in which the entire LED is exposed to thermal stress cannot be used for further processing, as the lens could get damaged.

Instead, a selective soldering method such as the use of a laser beam is recommended, in which only the solder connections at the leads experience the maximum solder temperature; the thermal stress for the entire LED remains low.

Printed Circuit Board (PCB)

When designing an appropriate thermal management for high power LEDs (see also application note "Thermal Management of Golden DRAGON LED"), the circuit board plays a key role. As a direct interface with contact to the LED, it significantly contributes to effective thermal transfer and heat dissipation. By selecting an appropriate

material with sufficient surface area, the circuit board itself can provide the cooling if required.

By examining the internal construction of Golden DRAGON® LED package (Figure 3), it can be seen that the semiconductor chip is directly mounted to an integrated metal heat slug, in order to provide better heat dissipation.

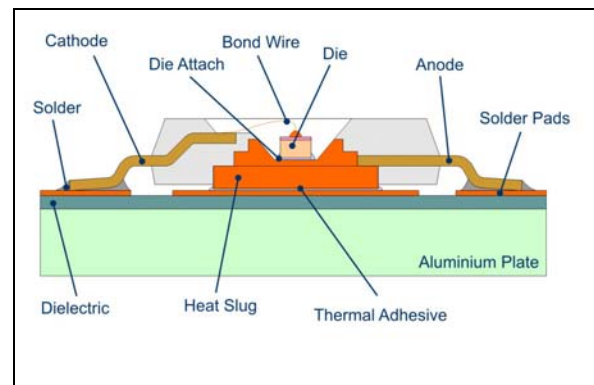

Figure 3: Internal construction of the Golden DRAGON® LED basic model

Since LEDs of the Golden DRAGON® product family can dissipate up to 2 Watts of power depending on the chosen operating parameters, additional heat transfer and dissipation by the circuit board is essential.

The choice of an appropriate material for the circuit board is therefore particularly important. Materials with insufficient heat transfer capability lead to a degradation in reliability and prevent operation at optimal performance levels, since the heat which arises cannot be sufficiently dissipated.

When constructing light sources with Golden DRAGON® LEDs, insulated metal substrate printed circuit boards (IMS-PCBs) are typically used.

Usually, these consist of an aluminum mounting plate, a thin dielectric insulator and a conductive layer of copper for electrical contact.

Flexible circuit board material can also be used in conjunction with a metal substrate. The combination with flexible circuit board material offers the advantage that a three-

dimensional light source design can be realized, for example.

Standard substrates such as FR4, for example, are normally not suitable for use with high power LEDs like those of the Golden DRAGON® family, due to their low heat transfer capability.

Tests at OSRAM OS with thin FR4 material in combination with thermal vias and additional cooling (e.g. an aluminum plate) show that this construction can also be used (Figure 4), if a good thermal connection is provided between the FR4 material and the cooling unit through the use of a thermal interface material (see also the application note "Thermal Management of Golden DRAGON® LED").

Compared to IMS-PCBs, a cost advantage of around a factor of 3 can be achieved.

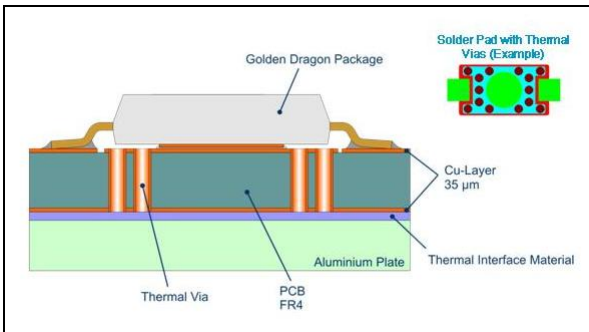

Figure 4: Cross section of FR4 with thermal vias

Solder Pad Design and Surface

When designing solder pads as a direct contact between the circuit board and the component, differing requirements should be taken into account.

The design goal is to achieve an optimal balance between processability, low positional tolerance and a reliable solder connection. In addition, the requirements for a good thermal management should also be fulfilled.

Figure 5 shows the general optimized solder pad design for the Golden DRAGON® ARGUS® LED.

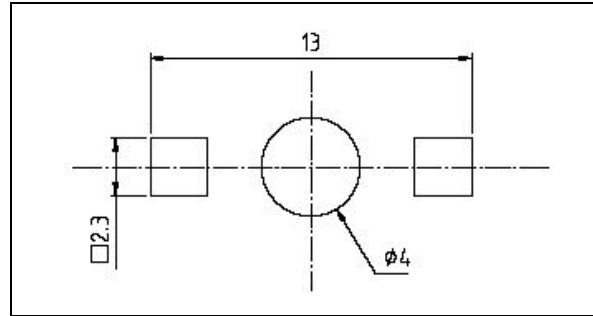

Figure 5: General solder pad design for the Golden DRAGON® ARGUS®

The specified design refers to the openings in the solder or adhesive mask, since for many applications the copper pads are usually larger in size.

To fulfill the requirements of a good thermal management with the high power Golden DRAGON® LEDs, the copper area around the integrated slug should be kept as large as possible. This serves to dissipate or spread the accumulated heat and is typically covered with a solder resist layer.

Additionally, care should be taken that the copper surface for the heat sink is insulated from other solder pads or heat sink surfaces, since the anode and heat sink of the Golden DRAGON® housing are electrically connected.

When the integrated heat sink of the Golden DRAGON® ARGUS® is attached with a thermally conductive adhesive, this design aspect is less critical. It is recommended, however, that the separation be maintained in order to prevent undesirable short circuits from occurring.

Figure 6 shows the recommended copper pad design of the Golden DRAGON® ARGUS® LED.

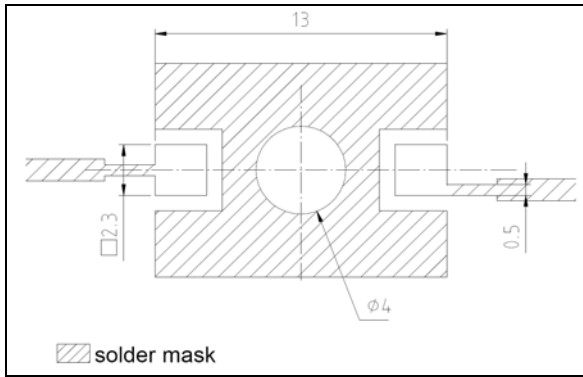

Figure 6: Recommended copper pad design for the Golden DRAGON® ARGUS® LED

The detail view (Figure 7) additionally shows the heat barrier between the solder pads and the electrical connections. Such a heat barrier is recommended in order to keep the heat introduced by soldering almost completely within the area of the solder pad. Larger connection paths would dissipate the heat away from the solder pad, making the soldering process more complicated.

It would be more difficult to achieve the necessary soldering temperature, and would increase the time required to form the solder connection.

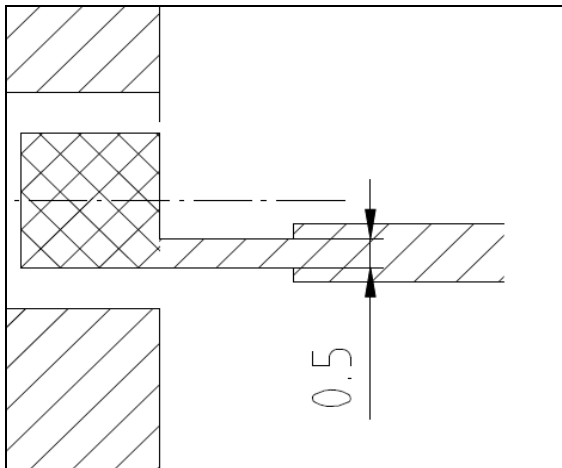

Figure 7: Heat Barrier between solder pad and electrical connection

Plating of the solder pad surfaces can be carried out with various types of materials:

- HAL lead free (Hot Air Leveling)
- OSP (Organic Solderability Preservative)
- Chemical Tin

Principal Assembly Steps

The general assembly process for the Golden DRAGON® ARGUS® LED differs only slightly from the conventional SMD soldering method.

In the following the individual processing steps, shown in Figure 8, are specified.

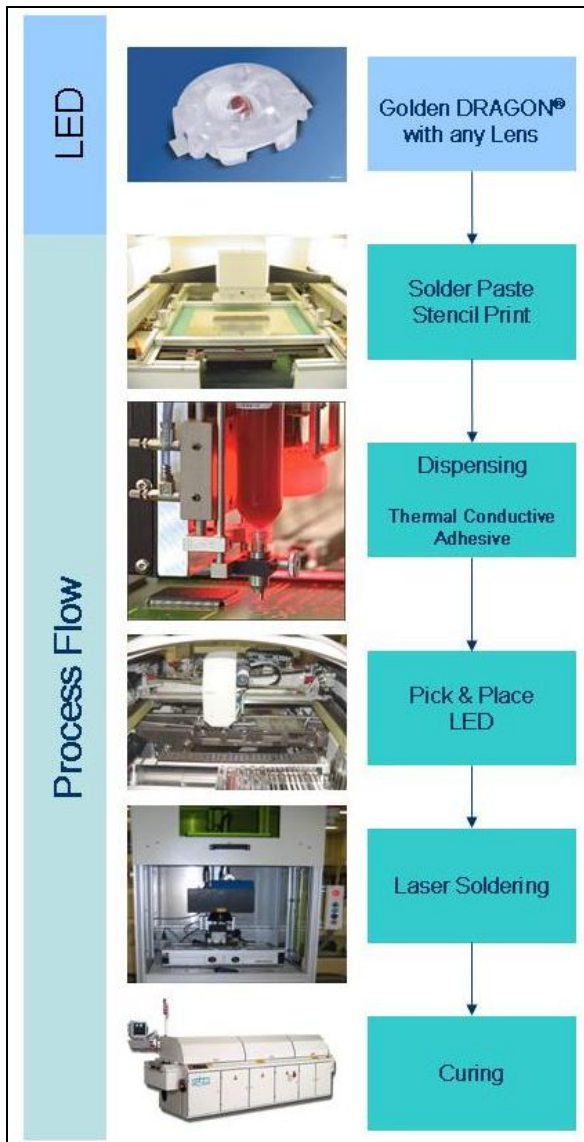

Figure 8: General assembly process flow for Golden DRAGON® ARGUS® LED

Compared to a standard soldering method, the Golden DRAGON® ARGUS® LED requires two additional processing steps. First of all, this includes the application of a thermally conductive adhesive, and

secondly, the curing of this adhesive at the end of the entire process. Both steps are necessary in order to achieve a thermal connection between the slug for the housing and the circuit board.

In general, however, all individual process steps are based on standard methods used for mounting semiconductor components.

Solder Paste Stencil Print

The application of solder paste has a significant influence on the solder quality of the component. Since it is the cause of around 60 - 70% of all failures which arise during the assembly process, this generally represents the most critical process in the entire chain.

To apply the solder paste, various methods are available:

- Silkscreen/Stencil Printing
- Dispensing

For large scale production, stencil printing has established itself as a standard due to the long operating lifetime of the stencil and its high processing speed.

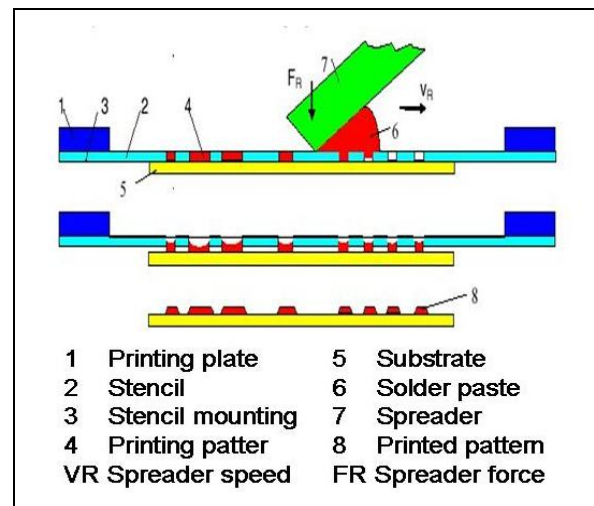

Figure 9: Stencil Printing - Functional Diagram

With stencil printing, the solder paste is transferred to the circuit board through the

laser-cut or etched stencil in a fashion similar to screen printing.

To apply the solder paste, a spreader traveling at a constant speed and a specific contact pressure is moved across the stencil, such that the rolling paste passes through the openings in the stencil and is printed onto the circuit board.

In order to achieve a high quality soldering, the paste must be applied in the exact position, geometry and volume required, without so called edge tears or smearing of the paste after the stencil is removed.

The volume of the printed solder paste is determined by the stencil aperture (opening of the stencil) and the stencil thickness.

For the Golden DRAGON[®] ARGUS[®] LED, it is recommended to use stencils with a thickness of 150 µm (in the range of 120 – 180 µm). Furthermore, laser cut (usually made from stainless steel (CrNi)) or electroformed stencils (Ni) are preferable.

A general recommendation for dimensioning the stencil openings cannot be provided, since the optimal geometry is dependent on additional parameters such as the composition and reflow characteristics of the solder paste, the wetting characteristics of the circuit board plating and component leads and the soldering method employed. The geometry of the solder pads and stencil openings should always be adapted to the respective customer requirements and specific process parameters.

In practice however, the stencil openings are often dimensioned to be 50 µm smaller than those for the solder pad, or a general 10 percent reduction in size.

Dispensing of Thermal Conductive Glue

Nowadays, the available dispensing methods can be subdivided into two main categories:

- board contact dispensing
- non-contact dispensing

The primary difference between the two categories is whether or not the dispensing unit is in contact with the circuit board during the process.

With the board contact method, the dispensing unit must be lowered to the level of the circuit board and raised again.

This movement in the z direction between the individual gluing steps is not present in the non-contact method. In this case, the adhesive is sprayed (jetted) onto the circuit board from a particular distance so that a point of glue (dot) is formed.

Although board contact dispensing methods (e.g. time/pressure dispensing, auger valve dispensing or positive displacement dispensing) are most commonly used, the trend is going towards non-contact dispensing (e.g. jet dispensing) methods. These offer several advantages over board contact procedures, such as:

- minimal stringing
- faster dispense cycling time due to elimination of Z-axis movement
- better dot reliability

When selecting a suitable thermal adhesive, there are several thermally conductive compounds available on the market with one or more components. In general however, it is strongly recommended to test the suitability of an adhesive before its use.

As a thermal adhesive for the mounting and thermal connection to the internal heat sink of the Golden DRAGON[®] ARGUS[®] LED, the adhesive AMICON E3503-01 from Emerson & Cuming is suitable, for example.

Since the performance of the LED is influenced by the adhesive, care should be taken that:

- the thermal conductivity of the adhesive is greater than 1 W/mK;
- the entire contact surface of the heat sink is moistened with adhesive;
- the film thickness is kept as low as possible (typically 50 µm, max. 70 µm);
- sufficient mechanical force is applied;

Pick & Place LED

For selecting and inserting the components, automatic placement devices with various methods such as Pick & Place or Collect & Place can be used.

The handling of the components within the machines is similar for the Pick & Place or Collect & Place methods.

The SMD components are delivered in rolled tapes and are automatically fed to the placement head. The placement head picks the component from the tape with a vacuum pipette and places it at the prescribed position on the circuit board.

Nozzle Design

During processing, mechanical stress to the surface of the encapsulant or lens should be minimized to the extent possible.

Essentially, a vacuum pipette which meets the requirements of each LED type should be used.

For population of the Golden DRAGON® ARGUS® LED, the use of special commercially available pipettes with a rubber coating on the collar is recommended.

The rubber coating provides an easy way to prevent scratching or damage to the primary optics.

Figure 10 shows an example of a Pick & Place nozzle for the Golden DRAGON® ARGUS® LED.

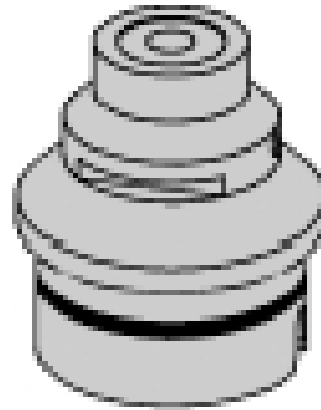

Figure 10: Sample for a Pick & Place nozzle for Golden DRAGON® ARGUS® LED

Selective Laser Soldering

Due to the material properties of the lens, it is not possible to process the Golden DRAGON® ARGUS® LED with a conventional standard soldering process. Instead, a selective soldering process by means of a laser is recommended for production.

In comparison to other selective soldering methods, laser technology offers several advantages:

- Precise positioning of the laser beam
- The energy required for soldering is selectively applied
- The solder temperature is very quickly achieved
- No overheating of the LED and lens
- Lower maintenance costs - no wear of soldering tips / dies
- No mechanical damage to the leads during soldering
- Controllability (temporal and spatial)
- Reliability
- Ease of automation

Thereby especially laser systems based on high power laser diodes are suitable for manufacturing process. Compared to other laser systems, these offer the advantages that they are small in size, efficiently convert electrical energy into photons, are more cost effective and are easier to operate.

Depending on the dimensions of the solder connections and the speed required, the average laser power needed lies in the range of up to 80 Watts, with a wavelength in the near IR range (800 - 970 nm).

The following Table 1 shows a few important parameters for laser soldering the Golden DRAGON® ARGUS® LED. The listed parameters are meant to serve as a basis, however, and should be verified with regard to the selected laser system, PCB material, layout, solder material, etc.

High Power Diode Laser Soldering	
Wavelength	~ 940 nm
Power	~20 - 30 W per solder pad
Pulse Duration	>1 sec.
Beam Geometry	~ Rectangular
Dimension	~ 2.3 x 2.3 mm
Pulse Form	

Table 1: Basic information for laser soldering of the Golden DRAGON® ARGUS® LED

For the soldering process itself, a few additional points, both product specific as well as material related, need to be taken into account.

Depending on the material used for the circuit board, preheating of the board is necessary, in order to achieve the required melting temperature of the solder during the soldering process.

For processing of Golden DRAGON® ARGUS® LEDs on IMS-PCBs, the board must be preheated to 80 to 90 °C, due to the high thermal capacity of the board. If FR4 with thermal vias is used, preheating can have a very advantageous effect on the soldering process.

Furthermore, the laser power must be individually adapted to the anode and cathode of the component. That is, when soldering the lead on the anode side, more energy is required, due to the internal connection to the slug, than for the cathode lead (see Figure 3, Internal Construction).

If this is not taken into account and both sides are soldered with the same high or low power, this can either lead to a melting of the LED housing at the cathode side (Figure 11, top) or lead to an insufficient solder

connection at the anode side, due to the low power used (Figure 11, bottom).

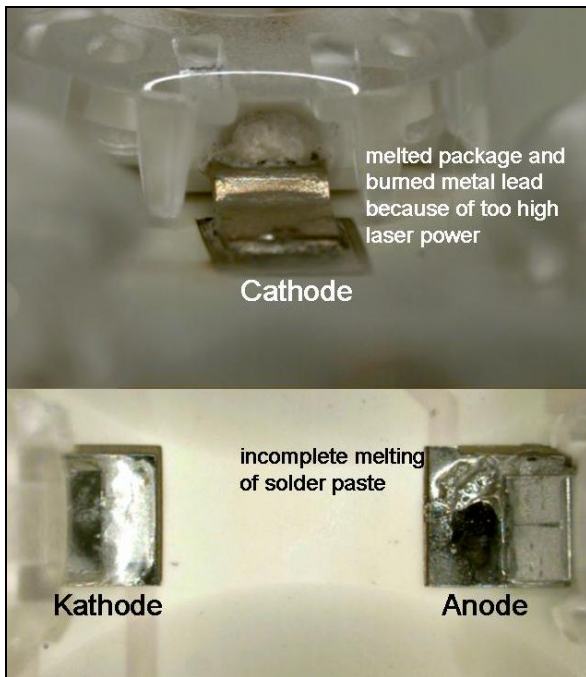

Figure 11: Possible failures during soldering process

Furthermore, during the soldering process, care should be taken that both leads, anode and cathode, are soldered in the same step, and thus simultaneously fixed to the board (Figure 12). This permits the self-centering effect to positively influence the alignment of the LED.

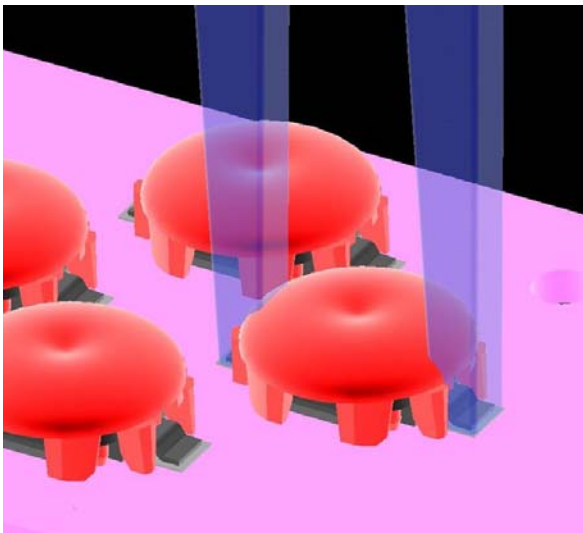

Figure 12: Principal Laser Soldering Process

If the leads are soldered individually, this can cause the LED to tip or stand upright ("tombstone" effect). In the worst case, the second lead cannot be soldered because it has risen too far from the solder pad.

In comparison, Figure 13 shows a good solder connection. As can be seen in the image, the entire solder melts simultaneously, and exhibits a good wetting of the contacts.



Figure 13: Good solder connection / laser soldering

When one compares the laser soldering process with a conventional standard IR-Reflow process, tests with the Golden DRAGON® device show equally good results. All tests listed in Table 2 carried out with the laser process resulted in no component errors or failures.

Also, with respect to mechanical rigidity, no difference was seen between completely soldered components and those which were adhesively soldered. The pull and shearing power show comparable values.

Mechanical Test		
Test Performed	Condition	Duration
Shock IEC 60068-2-27	500 g >4 ms	
Vibration IEC 60068-2-6	Sin 20 -1kHz > 20 g, 3 axes / 1.5 h each / 500 g >4 ms	
Temperature Cycle (TC) Temp cycle 2 chambers	T = -40 °C/125 °C t _{Extreme} = 15 min	1000 cycle
High Temperature Storage (HTS)	T = 125 °C	1000 h
Operating Test		
Test Performed	Condition	Duration
Steady state life test (SSLT) JESD22-A108	T _S = 85°C I _F = 700 mA (overstress)	1000 h
Steady state life test (SSLT) JESD22-A108	T _S = 85°C I _F = 400 mA (overstress)	1000 h
Steady state life test (SSLT) JESD22-A108	T _S = 55°C I _F = 400 mA	1000 h
Temperature & Humidity bias (T&HB) JESD22-A101	T _A = 60°C, r.H. = 90% I _F = 400 mA	1000 h

Table 2: Overview of Mechanical and Operating Tests

Glue Curing

In order to achieve final mechanical strength and a reliable thermal connection to the internal heat sink, a final process must be carried out so that the thermally conductive adhesive between the PCB and the Golden DRAGON® ARGUS® LED can cure.

Depending on availability, several systems (e.g. continuous furnace, furnace unit, furnace with an IR module, convection etc.) can be used for the curing process.

The curing process specified by the adhesive manufacturer should be followed; in any case, however, the maximum

processing temperature of 125°C for the Golden DRAGON® ARGUS® LED should not be exceeded.

The adhesive Amicon E3503-01 from Emerson & Cuming should be cured at 120°C for a period of 30 min, for example.

The color of the adhesive changes from cream color (off white) to beige during the process.

Since the LED system reaches its maximal rigidity after curing, reworking the board to fix soldering errors at this point becomes extremely difficult, often causing damage to the board or LED.

It is therefore recommended that the LED system be visually checked and the electrical function tested before the curing process.

Alternative Solder Technology

In addition to the previously mentioned laser soldering technique, there are other selective soldering methods such as robotic or manual hand soldering. In general, the Golden DRAGON® ARGUS® LED can also be processed with these methods.

Robotic Soldering Technique

In principle, the robotic soldering technique is an automated soldering with an automatic feed of the solder material (soldering wire). The mounting procedure corresponds to that of the manual hand soldering process (Figure 16). That is, soldering first occurs after application and curing of the thermal adhesive for the internal heat sink of the LED.

For the soldering process itself, the robotic soldering iron is moved to the solder location, lowered into position and the required amount of solder is simultaneously applied (Figure 14).

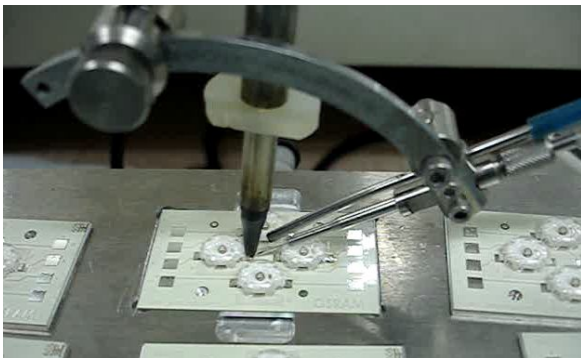

Figure 14: Robotic Soldering

Compared to other soldering methods, the automated hand soldering method requires the highest time expenditure. There is also a certain wear of the soldering tip associated with this method, which must be taken into account.

Due to the preferred use of an adhesive, possible rework of the board is very difficult, and most often can damage the board or LED.

As process parameters for the soldering procedure, the employment of manual hand soldering methods can be applied here. In addition, the basic recommendations for lead free soldering should also be observed.

Manual Hand Soldering for Prototyping

In addition to automated soldering methods, the Golden DRAGON® ARGUS® LEDs can also be hand soldered - for the construction of prototypes, for example.

The processing steps for manual soldering are basically the same as those for the automated process. The application of a solder paste is not required here, since the solder is applied manually during soldering. In general, it is recommended that the thermal adhesive be allowed to cure before manually soldering the LED.

This considerably facilitates the handling of the soldering iron. This also helps to prevent difficulties due to tipping, sliding or standing of the component.

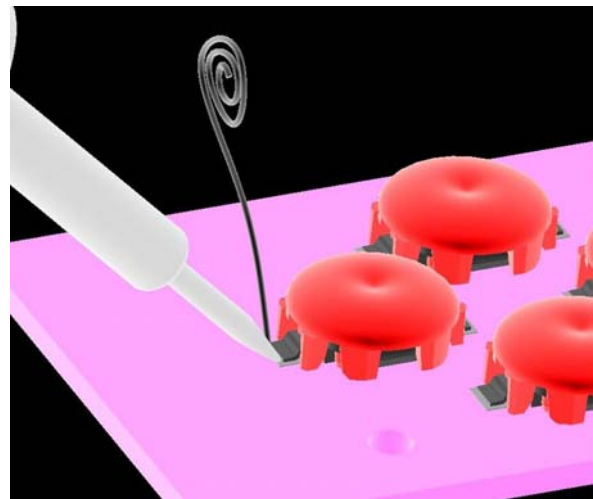

Figure 15: Manual soldering

Depending on the type of PCB (Insulated Metal Substrate-PCB or FR4 with thermal vias), preheating of the board by means of a heating plate may also be required.

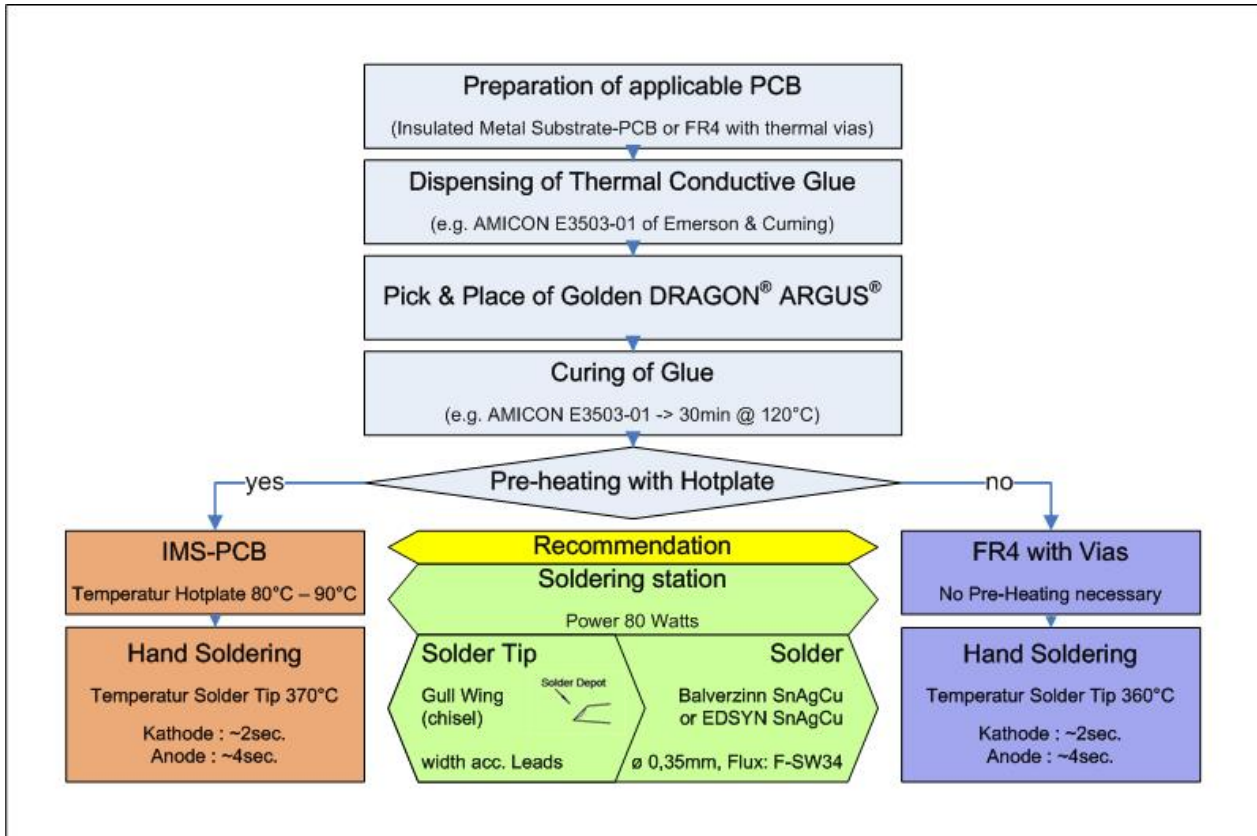

Figure 16: Recommended Hand Soldering Process for Golden DRAGON® ARGUS® LEDs

Care should also be taken not to damage the insulation layer of the PCB since this can lead to shunts or short circuits in the board.

In order to achieve good results when hand soldering with lead free solder, several fundamental points should be observed:

- Use soldering wire with a minimal diameter in order to obtain better flow characteristics;
- Keep the operating temperature as low as possible in order to prevent overheating of the LED;
- If possible, the shape and size of the soldering tip should be adapted to the geometry of the leads;
- The soldering tip should be well tinned in order to provide a good, large heat surface between the soldering tip and the solder location;

- The use of an intelligent soldering station with precise temperature and power control is strongly recommended;

Furthermore, all contact between the soldering iron and the optics of the LED should be avoided, since this can damage the plastic lens and ultimately lead to failure of the device.

Of the numerous types of soldering tips available, the use of a conical tip with a solder repository (gull wing) is recommended; alternatively, a chisel-shaped tip can be used.

Ideally, the width of the tip should approximately cover the width of the lead (1.8 mm).

Summary

For the development and construction of light elements with the Golden DRAGON[®] ARGUS[®] LED, there are basically several points to keep in mind:

- Due to the high power dissipation, an appropriate thermal management is absolutely necessary in order to guarantee optimal performance and lifetime of the LED (see also "Thermal Management of Golden DRAGON[®] LED");
- Solder pads have to be designed in such a way that the internal slug has no electrical contact to the neighboring LEDs;
- The heat sink cannot be soldered; instead, a thermal adhesive with low thermal resistance should be used;

- More energy is required when soldering the anode, due to its connection with the slug;
- Damage to the lens during the assembly process must be prevented;
- The maximum processing temperature of the primary optics is limited to 125 °C;

No degradation in performance of the Golden DRAGON[®] ARGUS[®] LED due to the extended assembly process could be observed.

The quality and reliability of laser soldered Golden DRAGON[®] ARGUS[®] LEDs are absolutely comparable to reflow soldered state of the art SMT LEDs

Authors: Andreas Stich, Kurt-Jürgen Lang, Michael Sailer

About Osram Opto Semiconductors

Osram Opto Semiconductors GmbH, Regensburg, is a wholly owned subsidiary of Osram GmbH, one of the world's three largest lamp manufacturers, and offers its customers a range of solutions based on semiconductor technology for lighting, sensor and visualisation applications. The company operates facilities in Regensburg (Germany), San José (USA) and Penang (Malaysia). Further information is available at www.osram-os.com.

All information contained in this document has been checked with the greatest care. OSRAM Opto Semiconductors GmbH can however, not be made liable for any damage that occurs in connection with the use of these contents.